

MB-BLS-2

SEWING INSTRUCTIONS



July 15, 2019
Designed by Autumn

Red Cordura

Back

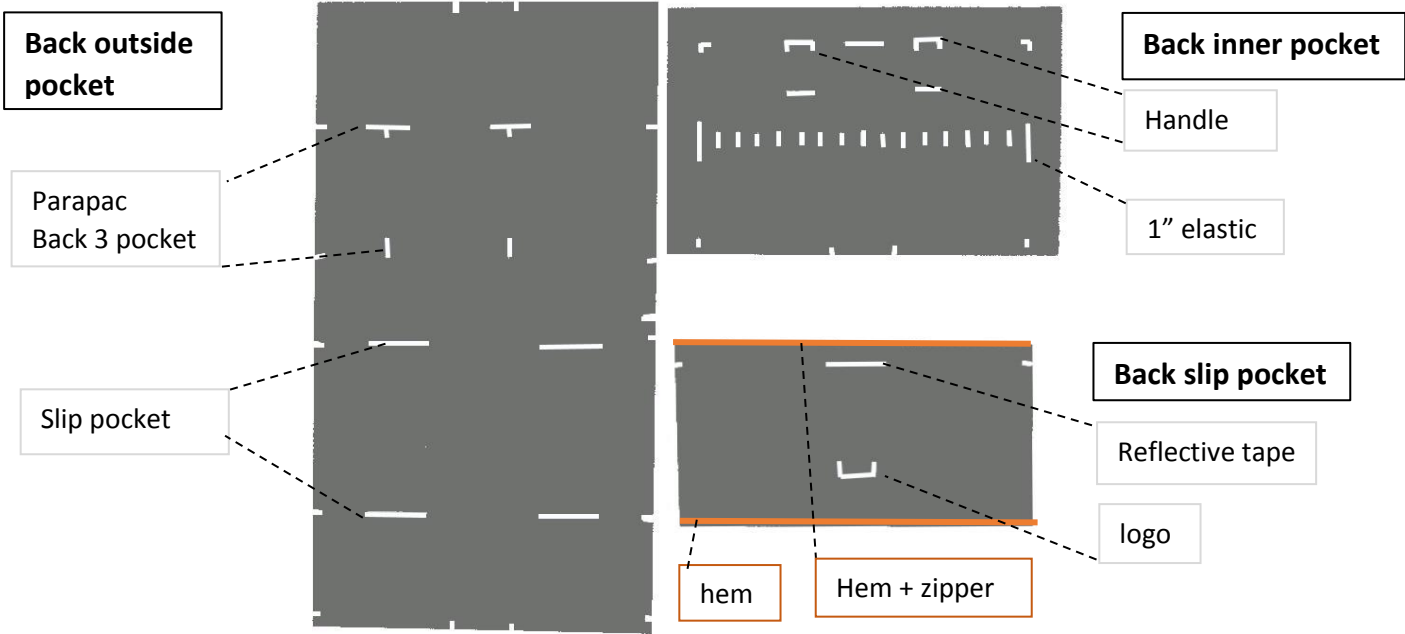

Front

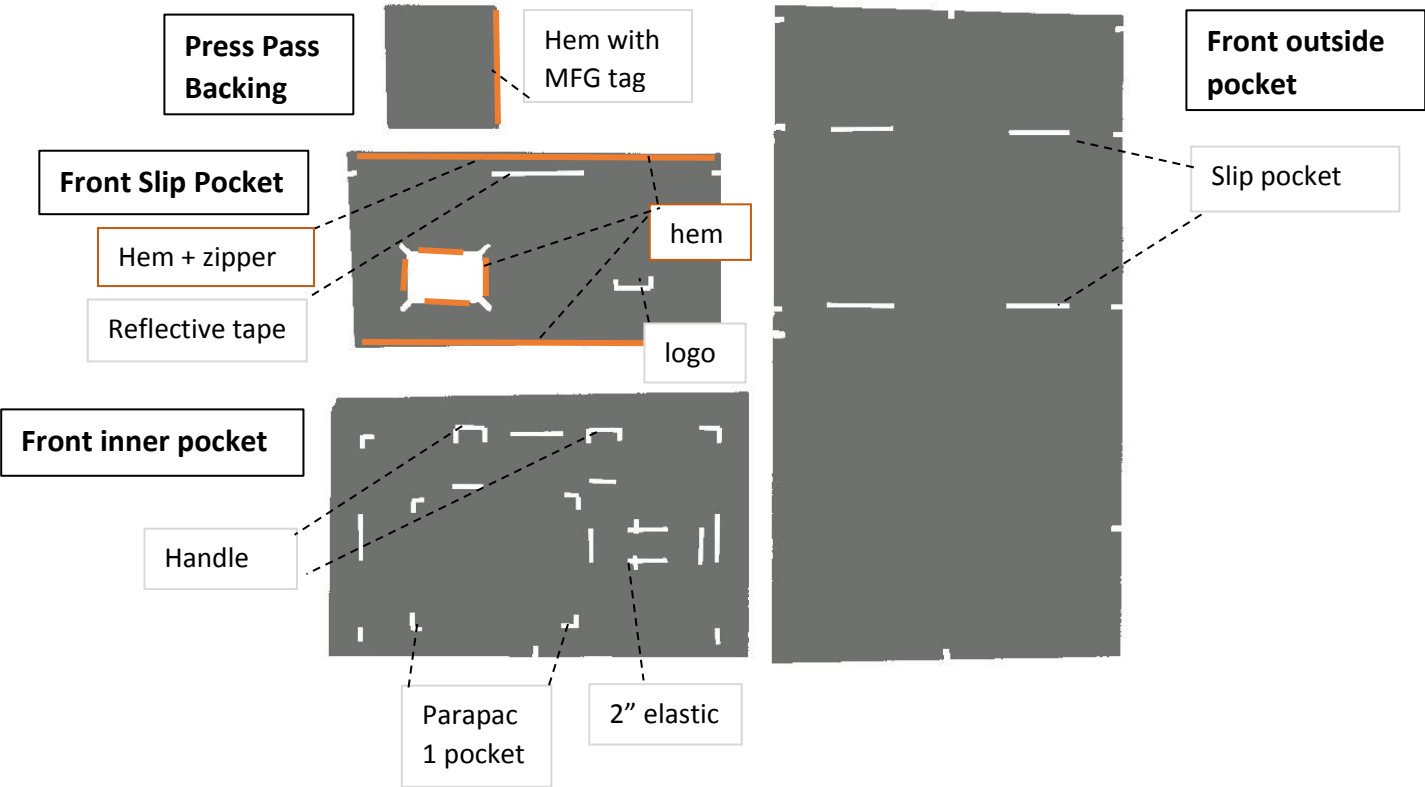

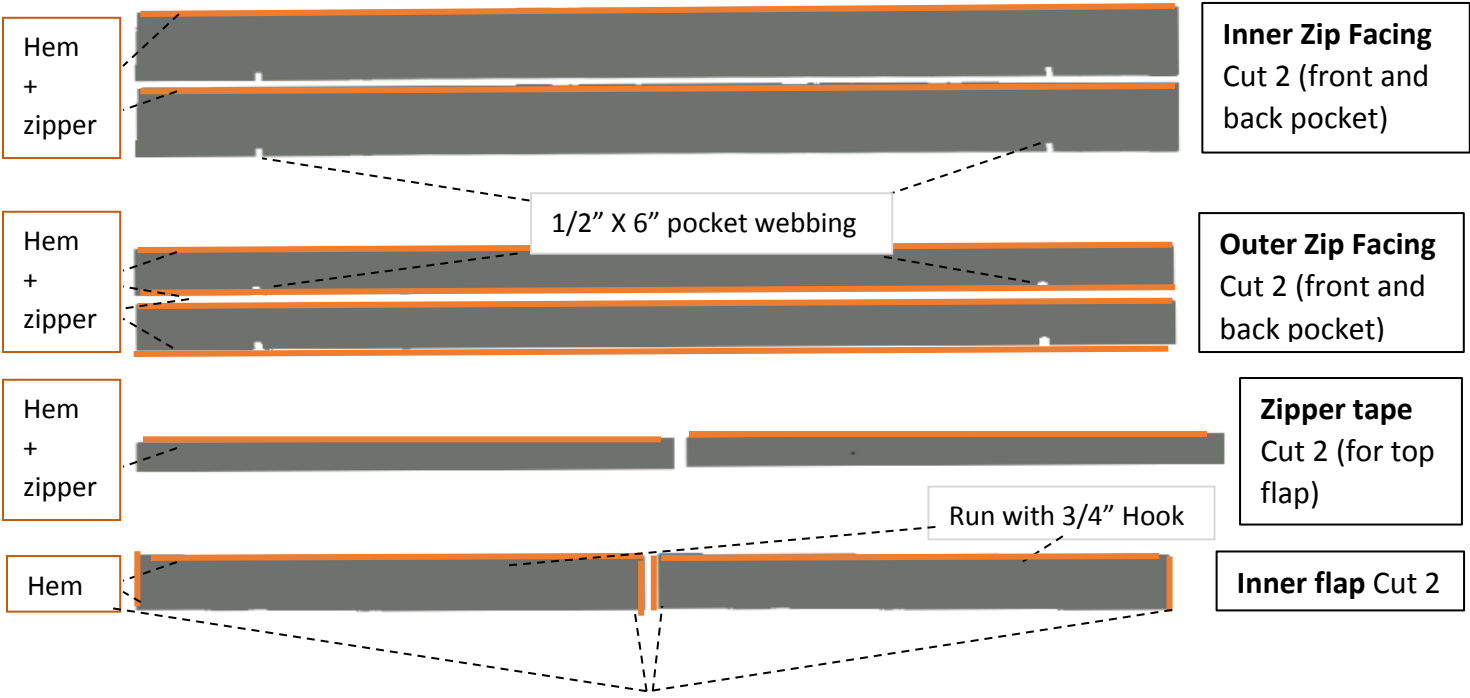
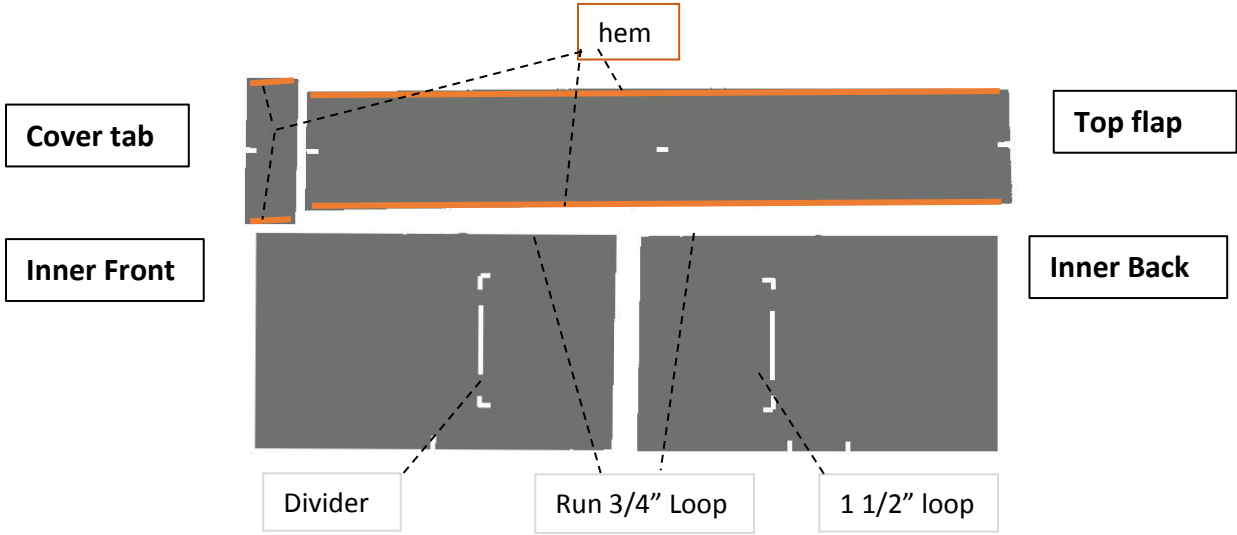

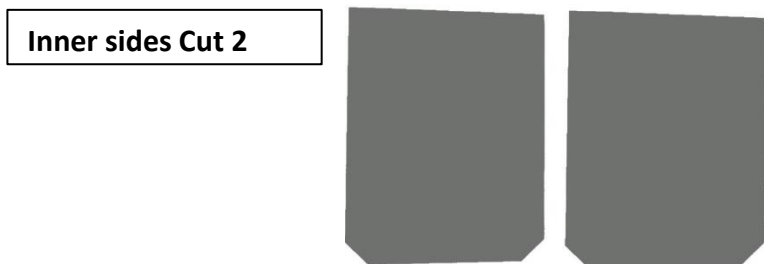
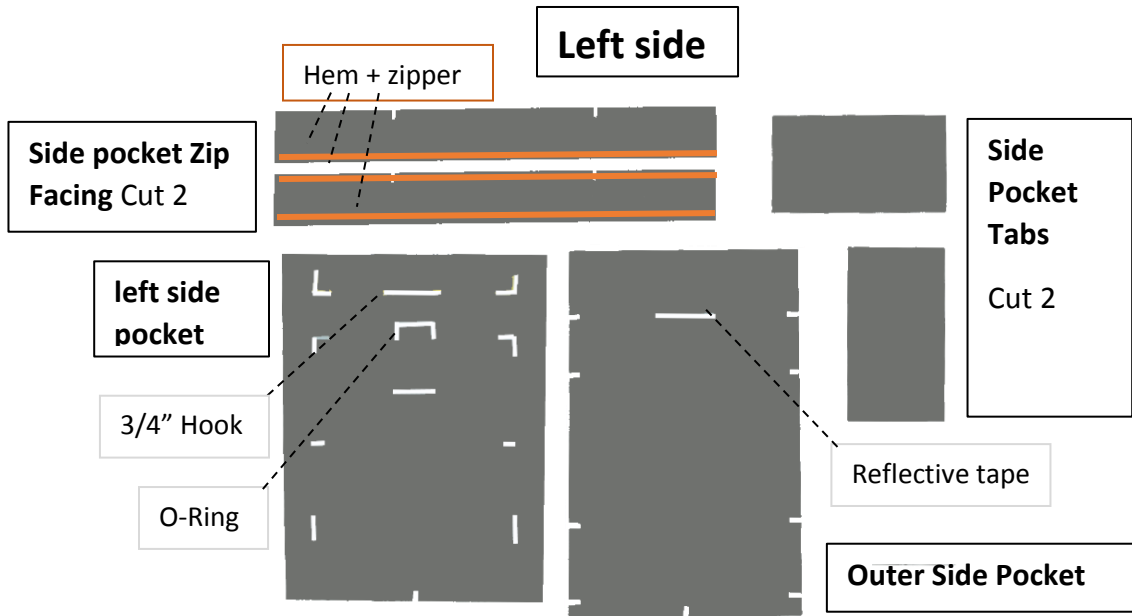
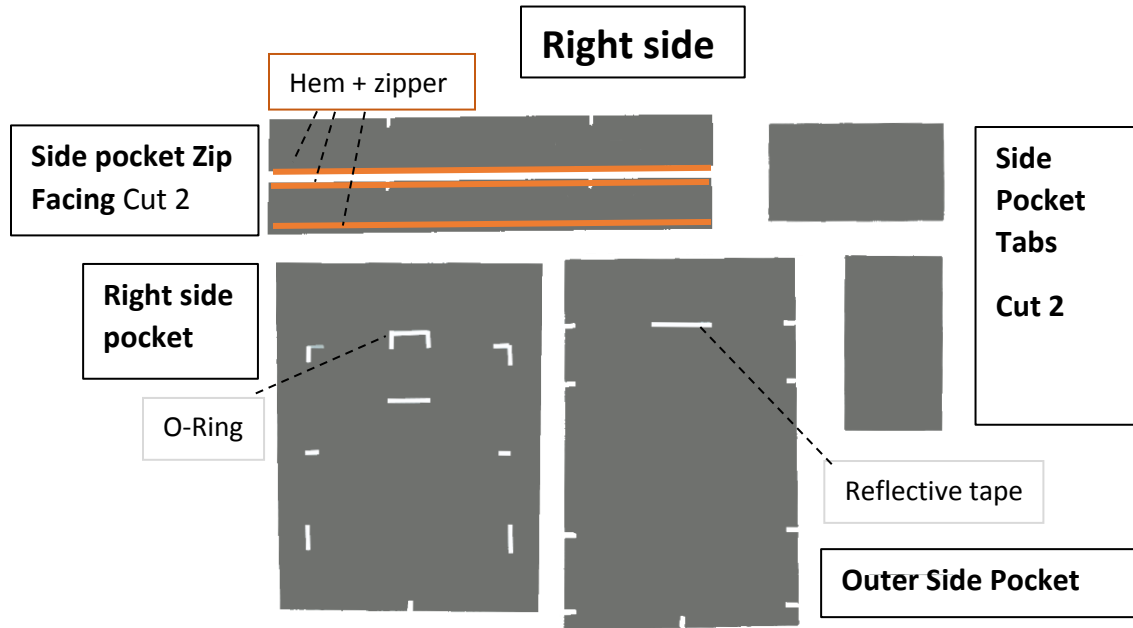

Gray Parapac

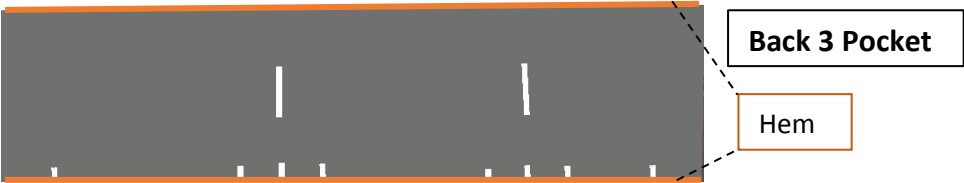
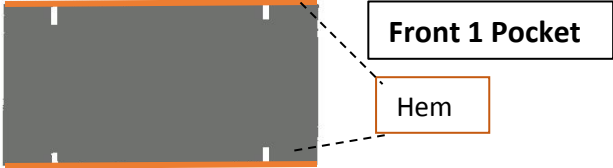

Other Materials

Bottom
Slip Not Dot



Bottom
Veltex with
Adhesive
Backing

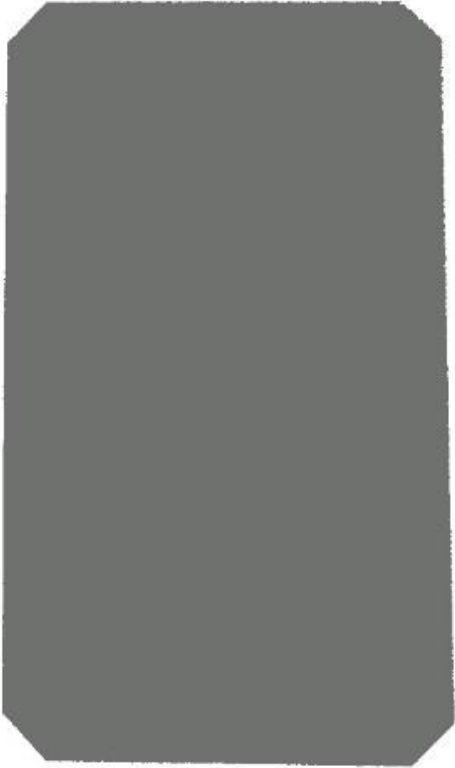

**Press Pass
Window**
Vinyl

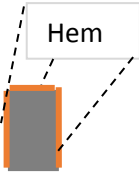

Handle Cover
Vinyl

3/4 Etha Foam

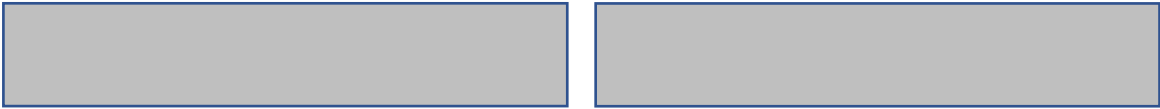

Pocket Bottom 3 5/8 X 15 Cut 2

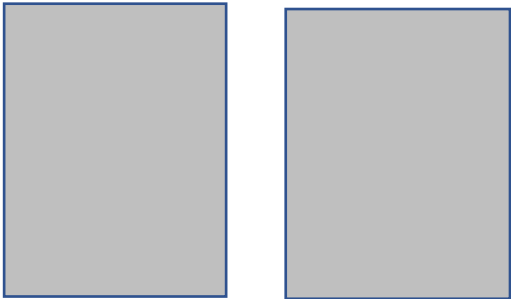

Sides
6 1/2 X 10 7/8

Cut 2

Corrugated plastic 8mm

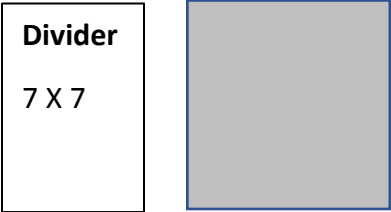

Divider
7 X 7

Sew up

1. **Hem** the top and bottom of the **Slip Pockets**
2. On the **Slip Pockets** set the logos, reflective tape, and press pass pocket with MFG tag on the back
3. Top stitch #10 zipper to the top. Add 2 zipper slides

Back



Back / Front

#10 revers zipper + 2 slides

Front



Reflective tape

4. Set the **Slip Pockets** on the **Out Side Pocket** on marks. Making sure the pocket with the press pass window is on the **Front Pocket**.
5. **Hem** the top and bottom of the gray Parapac **Back 3 Pockets**.
6. Set **Back 3 Pockets** on the **Back Out Side Pocket** folding on the marks to make the pocket puffy.
7. **Hem Out Side Pocket** where it is clip in and run 3/4" hook on the inside
8. On the wrong side marks run 3/4" loop on the wrong side.
9. Fold the **Out Side Pocket** in half and baste. Sew under the slip pocket and sew in the **Bottom Pocket** foam.

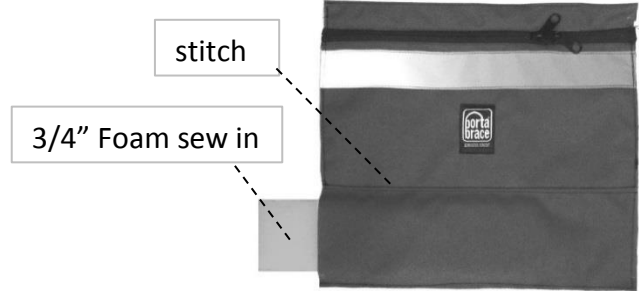
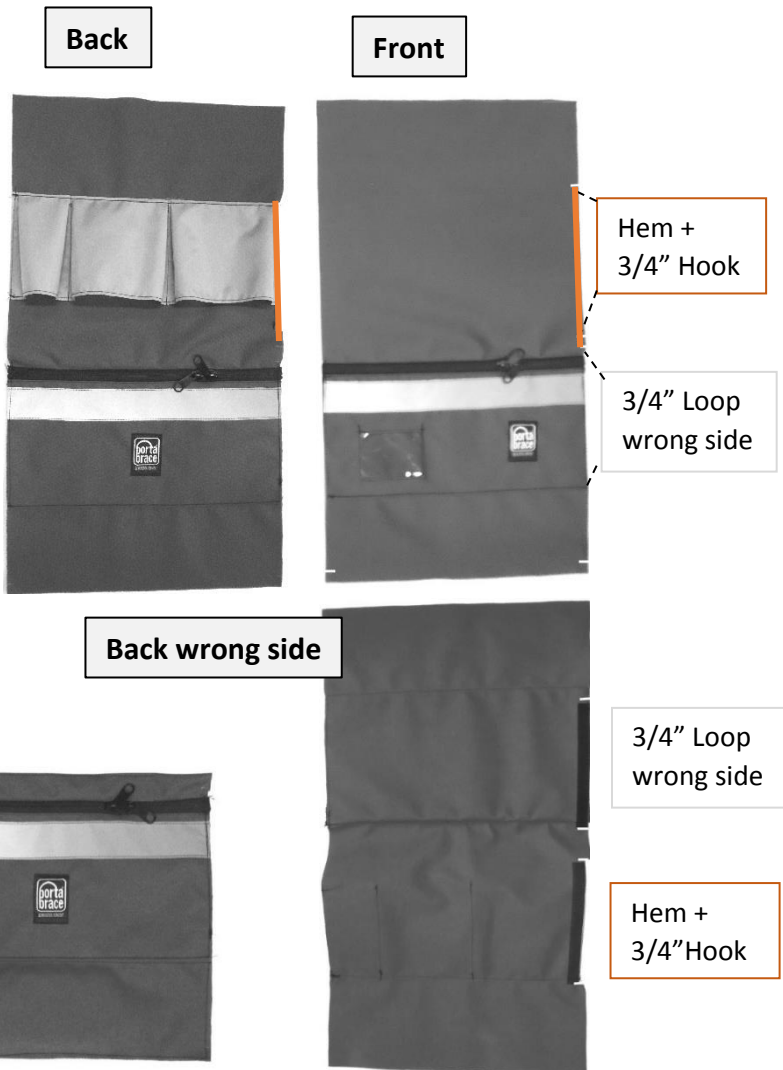

10. **Hem** Inner Zip Facing on side with no marks
11. **Hem** Outer Zip Facing on both sides
12. **Inner** and **Back Front Pockets** get handles set with the automatic machine
13. Set the zipper on the **Zipper Facing** with two #10 zipper slides
14. Z-tack 1/2" X 6" webbing on the zipper facing on marks
15. Set the zipper and **Facing** on the **Out Side Pocket**

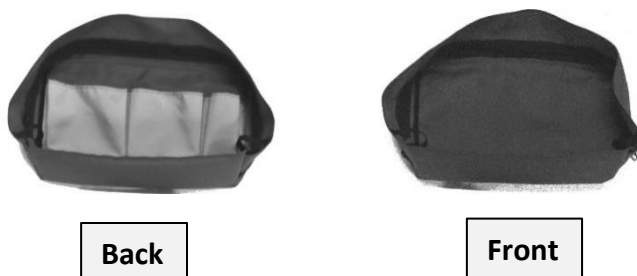
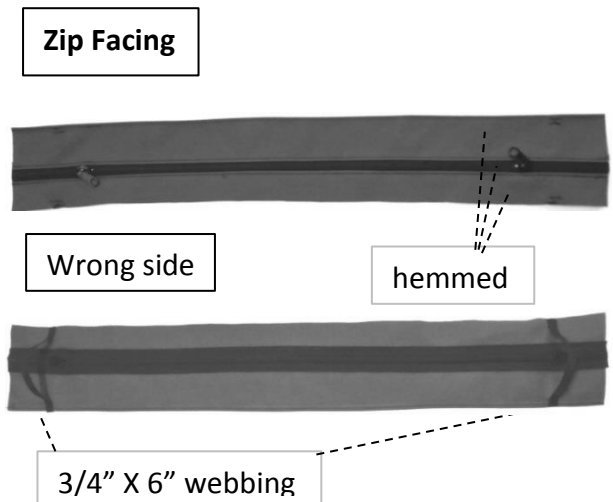

16. **Hem** all around the gray Parapac **Front 1 pocket**
17. **Front Inner Pockets** gets the Parapac **Front 1 pocket** set on folding at marks so the pocket is puffy.
18. Set the 2" elastic on **Front Inner Pockets**. **Hem** the ends of the elastic and sew down on the mark. The elastic should be puffy and have lots of space like 3 - 5 fingers.
19. Set the 1" elastic on **Back Inner Pockets** **Hem** the ends of the elastic and sew down on the mark. The elastic should be puffy and can easily fit a fingers width.

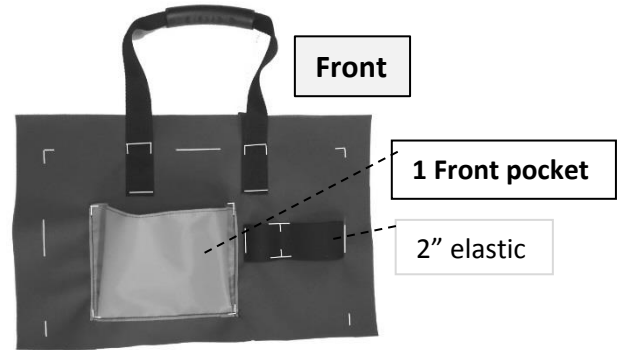
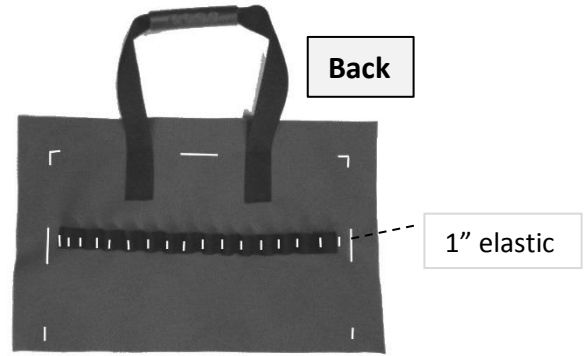

20. Finally set the pocket on the **Inner Pockets** making sure the bottom marks match – one center mark are **Front** patterns two bottom marks are **Back** patterns

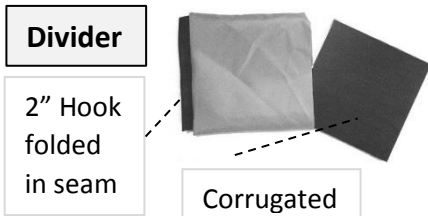
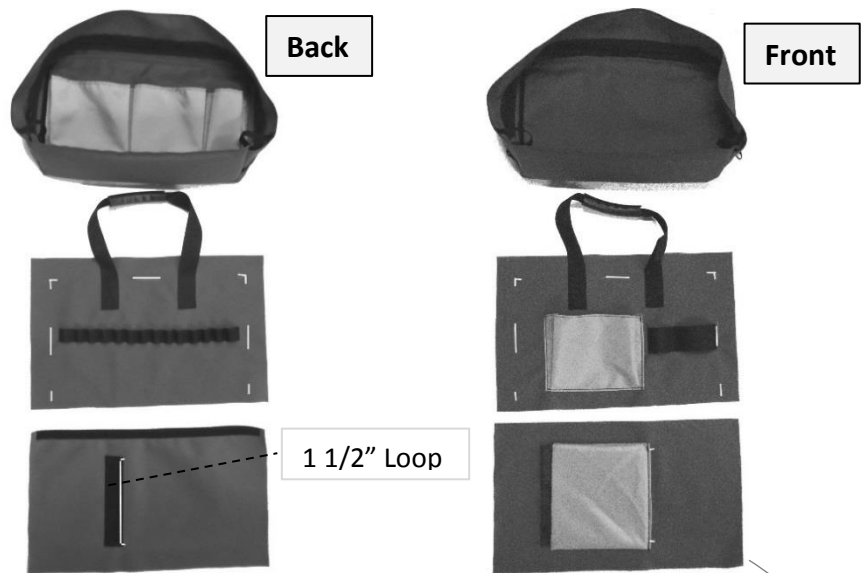

21. Divider gets folded in half, stick 2" Hook into the seam. Flip right side out and stuff the corrugated Plastic finishing it with a top stitch closed.
22. Both **Inners** get 3/4" Loop run on top
23. **Inner Back** gets 1 1/2" loop on marks
24. **Inner Front** gets the divider top stitched on to marks
25. Baste the **inner** and the **fronts** together leaving the top open
26. Nicely done! Moving on

1. **Hem** zipper facings and set zipper with two 10# slides
2. **O Ring** set with the automatic machine
3. Run reflective tape
4. Left Side Pocket gets 3/4" Hook set on marks
5. Sew together the **zipper with zipper facing** to the **Side Pocket tab**
6. sew together zipper facing and pocket
7. set pocket on side
8. whoopity doo your cool!

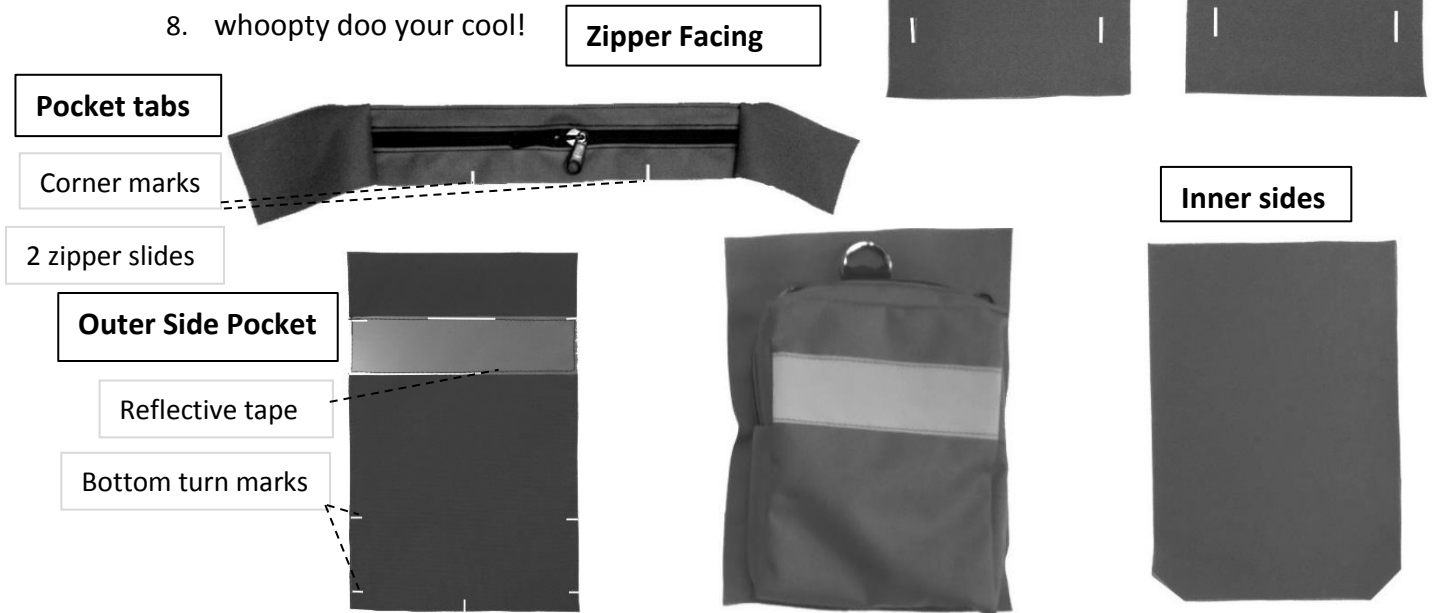

1. Take the 3/4" X 6" webbing and loop it through the one zipper slides. The slide should be about 4" apart. Baste the raw edges of the webbing to its self so the zipper slide on its own loop.
2. Take the **Vinyl Handle** cover and lay it on reflective tape. Hem the vinyl around the tape. You can leave a shorter side raw
3. Rap the handle around the webbing with the slides on it. Sew it in place

top



4. Fold the top in half and **Hem** the long sides, top stitch zipper
5. **Hem** one side of **Zipper Tape** and top stitch it to the zipper
6. But the Zipper slide on
7. Seam **Cover Tab To Top Flap**, matching Marks, Then hem setting 1 1/2" Loop

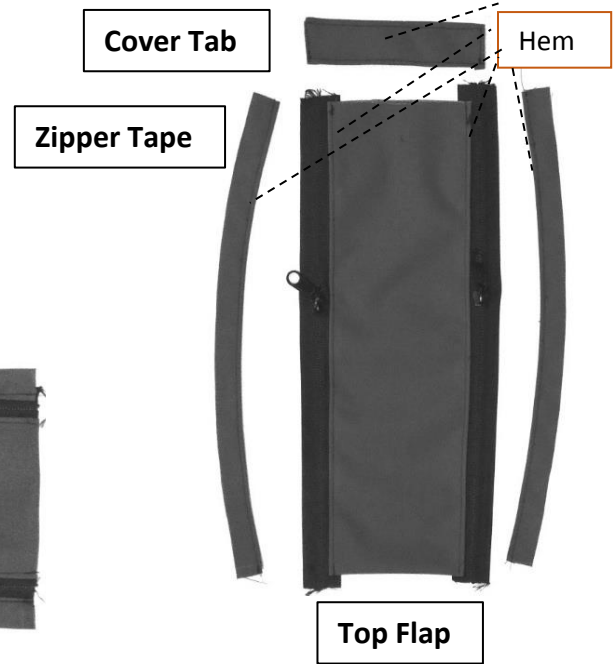

1. Hem the Inner Flaps with 3/4 hook
2. Take the **Top** and **Sides** and **Inner Sided** and sew together, right side of **Sides** and **Inner Sides** face each other with the **Top** sandwiched in. make sure to back tack over the zipper and burn and trim it
3. Flip the sides and baste them together leaving the bottom open for stuffing later. Top stitching the top down
4. Sew the slip not dot on the bottom maks sure the bottom makes are facing the front/back properly
5. Sew the **Front** and **Back** making sure you keep your 3/8 seam allowance.
6. Sew the **Inner Flaps** in covering the raw edges
7. Stuff the sides sew the foam in and flip
8. Woza your done go give your self a break!





END OF INSTRUCTIONS